

EUROPEAN STANDARD

EN 1997-1:2004/AC

NORME EUROPÉENNE

February 2009

EUROPÄISCHE NORM

Février 2009

Februar 2009

ICS 93.020; 91.010.30

English version
Version Française
Deutsche Fassung

Eurocode 7: Geotechnical design - Part 1: General rules

Eurocode 7: Calcul géotechnique - Partie 1:
Règles générales

Eurocode 7 - Entwurf, Berechnung und
Bemessung in der Geotechnik - Teil 1:
Allgemeine Regeln

This corrigendum becomes effective on 18 February 2009 for incorporation in the three official language versions of the EN.

Ce corrigendum prendra effet le 18 février 2009 pour incorporation dans les trois versions linguistiques officielles de la EN.

Die Berichtigung tritt am 18. Februar 2009 zur Einarbeitung in die drei offiziellen Sprachfassungen der EN in Kraft.



EUROPEAN COMMITTEE FOR STANDARDIZATION
COMITÉ EUROPÉEN DE NORMALISATION
EUROPÄISCHES KOMITEE FÜR NORMUNG

Management Centre: Avenue Marnix 17, B-1000 Brussels

© 2009 CEN All rights of exploitation in any form and by any means reserved worldwide for CEN national Members.
Tous droits d'exploitation sous quelque forme et de quelque manière que ce soit réservés dans le monde entier aux membres nationaux du CEN.
Alle Rechte der Verwertung, gleich in welcher Form und in welchem Verfahren, sind weltweit den nationalen Mitgliedern von CEN vorbehalten.

Ref. No.: EN 1997-1:2004/AC:2009 D/E/F

1 Modification to Foreword

Last subpart "National Annex for EN 1997-1", last paragraph including the list of national choice, add between "2.4.7.1(3)" and "2.4.7.2(2)P":

"2.4.7.1(4), 2.4.7.1(5), 2.4.7.1(6)"

and between "8.6(4)" and "11.5.1(1)P":

"10.2 (3)".

2 Modification to Subclause 1.1.2

Part (3), 1st indent, replace: "partial safety factor" with "partial factor".

3 Modifications to Subclause 1.6

Part "Latin letters":

Read the explanation of the following symbols as follows:

"A' effective base area ($A' = B' \times L'$)"

" $q_{b;k}$ characteristic value of unit base resistance"

" $q_{s,i;k}$ characteristic value of unit shaft resistance in stratum i ".

Replace as symbol for "width of a foundation": " b " with " B ".

Replace in the explanation of " C_d ": "effect of an action" with "relevant serviceability criterion".

Replace as symbol for "foundation length": " l " with " L ".

Insert the following symbol in the list after " $q_{s,r;k}$ ":

" q_u unconfined compressive strength".

Part "Greek letters":

Read the explanation of the following symbols as follows:

" $\gamma_{R,e}$ partial factor for passive earth resistance"

" $\gamma_{Q,dst}$ partial factor for a variable destabilising action"

" $\gamma_{Q,stb}$ partial factor for a variable stabilising action".

4 Modification to Subclause 2.1

Part (17), replace: "soil" with "ground".

5 Modification to Subclause 2.4.2

Part (4), 3rd dash, delete: "and ground-water pressure".

6 Modifications to Subclause 2.4.7.1

Part (4), add the following note:

"NOTE The values of partial factors may be set by the National Annex."

Part (5), add the following note:

"NOTE The values of partial factors may be set by the National Annex."

Part (6), add the following note:

"NOTE The values of model factors may be set by the National Annex."

7 Modification to Subclause 6.5.3

Part (11)P, replace in formulas (6.4a) and (6.4b): " A_c " with " A ".

8 Modification to Subclause 7.1

Part (3)P, delete the "NOTE" and add: " — EN 14199:2005, for micropiles".

9 Modification to Subclause 7.6.2.1

Part (13), 2nd dash, replace: "cross-sectional" with "gross cross-sectional".

10 Modification to Subclause 7.6.3.3

Part (6), "NOTE", replace: "from" with "in".

11 Modifications to Subclause 7.6.4.2

Part (1)P, replace: "partial safety factors" with "partial factors".

Part (4), replace: "assessed on" with "assessed on the basis of".

12 Modifications to Subclause 7.8

Part (4)P, replace: "very weak" with "extremely low strength fine".

Part (5), replace: "representative, undrained" with "characteristic".

13 Modification to Subclause 7.9

Part (4), add after "EN 12699:2000,"; "EN 14199:2005,"; and delete the final "NOTE".

14 Modifications to Subclause 8.1.1

Part (3):

Replace: "(3)" with "(3)P".

Replace the sentence:

"This Section should not be applied to soil nails."

with the following:

"This Section does not apply to soil nails."

15 Modification to Subclause 8.1.2

"8.2.1.7 Tendon free length", *renumber "8.2.1.7" into "8.1.2.7".*

16 Modification to Subclause 8.8

Part (1)P, replace: "It shall be specified in the design that all" with "All".

17 Modification to Subclause 9.3.1.5

Part (1)P, delete: "forces" after "ice".

18 Modification to Subclause 9.3.2.2

Part (3), replace: "execution period" with "design situation".

19 Modification to Subclause 9.5.3

Part (2), replace: "high angles of internal friction" with "high angles of shearing resistance".

20 Modifications to Subclause 9.6

Part (3)P:

Replace: "(3)P" with "(3)".

Replace the two occurrences of: "shall" with "should normally".

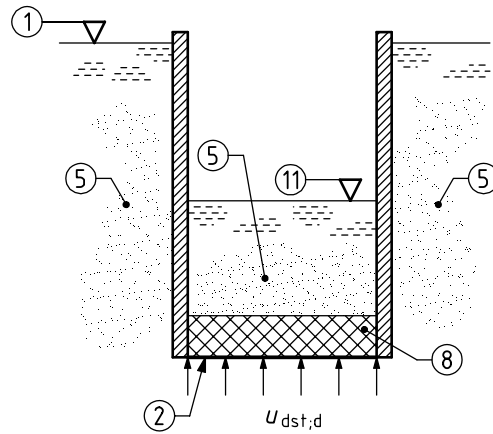

Figure 10.1 d)

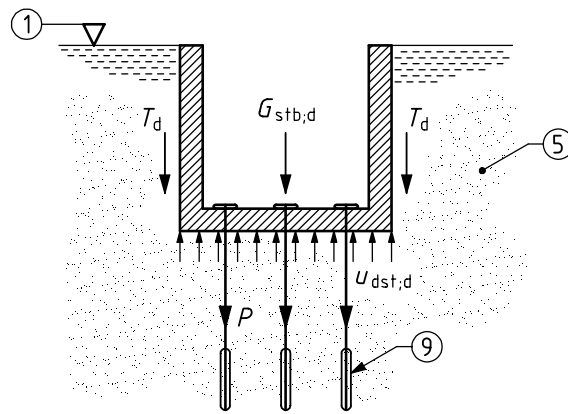

Figure 10.1 e)

Figure 10.1 c), add the key element:

“10 groundwater level before the excavation”.

Figures 10.1 c) and d), add the key element:

“11 groundwater level in the excavation”.

In Figure 10.1 c), add the key element:

“12 piezometric level at the base of the clay layer”.

In Figure 10.1 d), delete the key element:

“6 sand”.

24 Modification to Subclause 10.3

Figure 10.2, replace key element 1: “excavation level (left); water table (right)” with “excavation level (left); free-water level (right)”.

25 Modification to Subclause 10.4

Part (5)P, replace the current paragraph with:

"If the filter criteria are not satisfied, it shall be verified that the design value of the hydraulic gradient is well below the critical hydraulic gradient at which soil particles begin to move."

26 Modifications to Subclause 10.5

Part (1)P:

Figure 10.3, replace key element 1: "free water table" with "free-water level".

"NOTE", 2nd dash, delete underlining of "the".

27 Modifications to Subclause 11.5.1

Part (10), replace the 2nd sentence with: "If a method of slices is used and horizontal equilibrium is not checked, the inter-slices forces should be assumed to be horizontal."

Part (11)P, delete the final "NOTE".

28 Modification to Subclause A.5

Part (1)P, NOTE, replace: "EN 1990:2002" with "this standard".

29 Modifications to Subclause B.2

Part (4):

Replace: "Equation (2.6) includes" with "Equations (2.6a) and (2.6b) include".

Part (5):,

2nd paragraph, replace: "equation (2.6)" with "equations (2.6a) and (2.6b)".

5th paragraph, replace: "equation (2.6) reduces to" with "equation (2.6a) applies".

Part (6):

2nd paragraph replace: "equation (2.6) reduces to:" with "equations (2.6a) and (2.6b) reduce to:".

Part (7):

Replace: "equation (2.6) remains:" with "equations (2.6a) and (2.6b) remain:".

30 Modifications to Subclause B.3

Part (1):

1st line, replace: "equation (2.7)" with "equation (2.7c)".

EN 1997-1:2004/AC:2009 (E)

Equation (B.5.2), replace: "equation (2.7)" with "equation (2.7c)".

Part (2):

Replace: "equation (2.7)" with "equations (2.7a), (2.7b) and (2.7c)".

Part (5):

2nd paragraph, replace: "equation (2.7)" with "equation (2.7c)".

31 Modification to Subclause F.2

Equation (F.1), replace: "b" with "B".

32 Modification to Annex C

Replace the full Annex C with the following new Annex C:

Annex C (informative)

Sample procedures to determine earth pressures

C.1 Limit values of earth pressure

(1) The limit values of earth pressure on a vertical wall, caused by soil of weight density (γ), uniform vertical surface load (q), angle of shearing resistance (φ) and cohesion (c) should be calculated as follows:

— active limit state:

$$\sigma_a(z) = K_a \left[\int \gamma dz + q - u \right] + u - c K_{ac} \quad (\text{C.1})$$

where the integration is taken from ground surface to depth z

$$K_{ac} = 2\sqrt{[K_a(1+a/c)]}, \text{ limited to } 2,56\sqrt{K_a}$$

— passive limit state:

$$\sigma_p(z) = K_p \left[\int \gamma dz + q - u \right] + u + c K_{pc} \quad (\text{C.2})$$

where the integration is taken from ground surface to depth z

$$K_{pc} = 2\sqrt{[K_p(1+a/c)]}, \text{ limited to } 2,56\sqrt{K_p}$$

where:

- a is the adhesion (between ground and wall)
- c is the cohesion
- K_a is the coefficient of effective horizontal active earth pressure
- K_p is the coefficient of effective horizontal passive earth pressure
- q is the vertical surface load
- z is the distance down the face of the wall
- β is the slope angle of the ground behind the wall (upward positive)
- δ is the angle of shearing resistance between ground and wall
- γ is the total weight density of retained ground
- $\sigma_a(z)$ is the total stress normal to the wall at depth z (active limit state)
- $\sigma_p(z)$ is the total stress normal to the wall at depth z (passive limit state)

(2) For drained soil, K_a and K_p are functions of angle of shearing resistance φ' , and $c = c'$, the effective cohesion. For undrained soil, $K_a = K_p = 1$ and $c = c_u$, the undrained shear strength.

(3) Values of the effective earth pressure coefficients may be taken from Figures C.1.1 to C.1.4 for K_a and C.2.1 to C.2.4 for K_p .

(4) Alternatively, the analytical procedure described in C.2 may be used.

(5) In layered soils, the coefficients K should normally be determined by the shear strength parameters at depth z only, independent of the values at other depths.

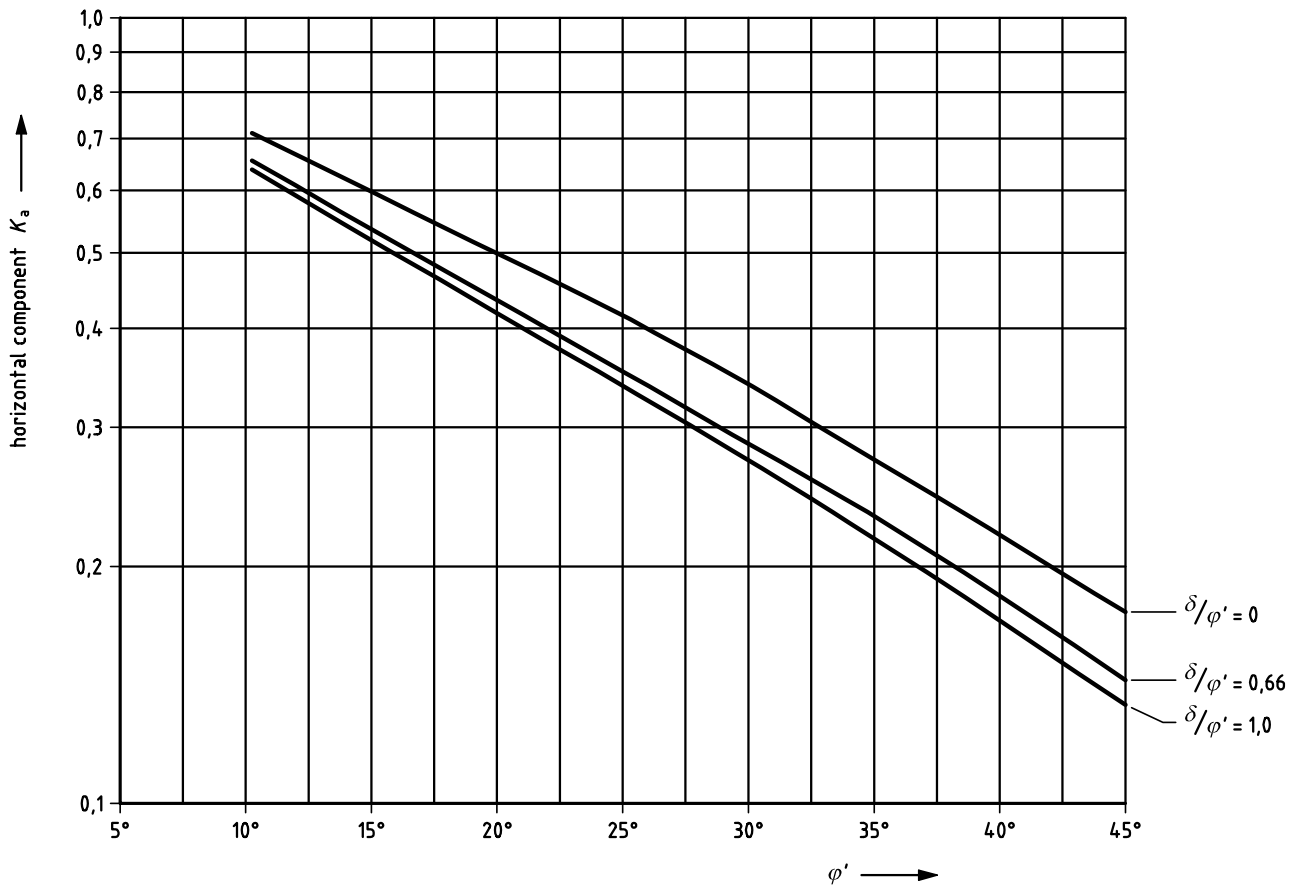
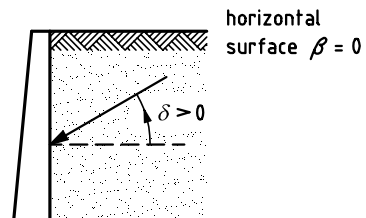

Figure C.1.1 — Coefficients K_a of effective active earth pressure (horizontal component): with horizontal retained surface ($\beta = 0$)

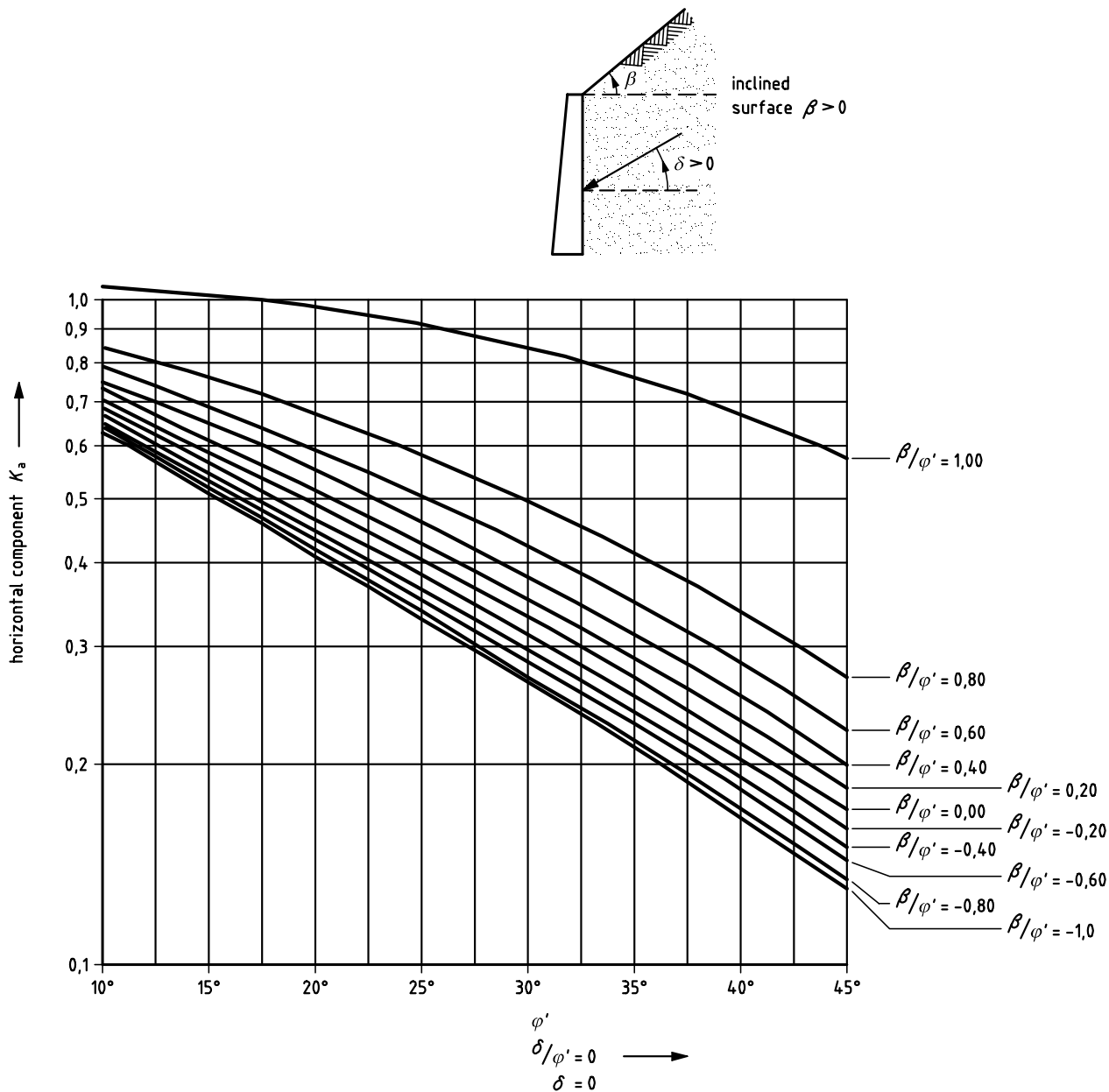

Figure C.1.2 — Coefficients K_a of effective active earth pressure (horizontal component): with inclined retained surface ($\delta/\varphi' = 0$ and $\delta = 0$)

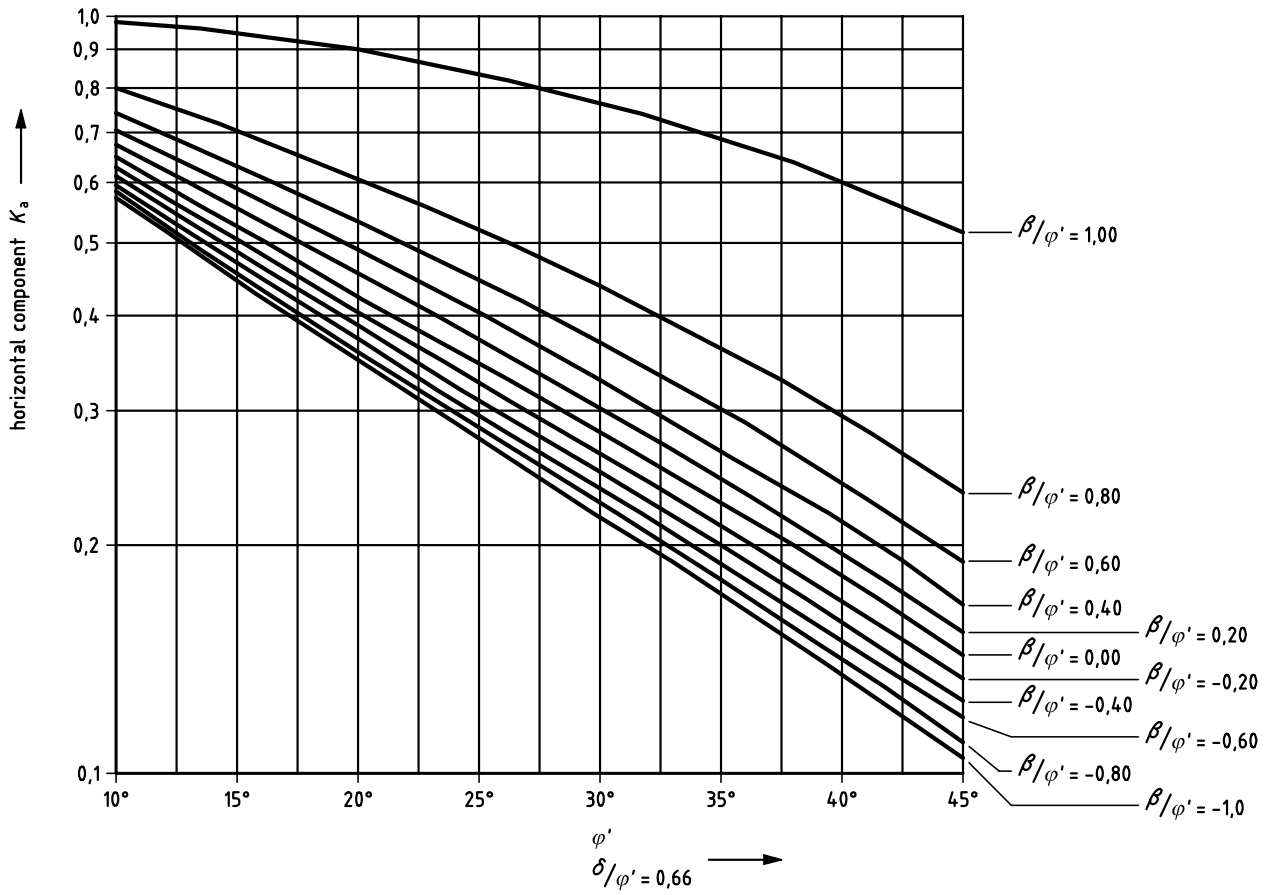
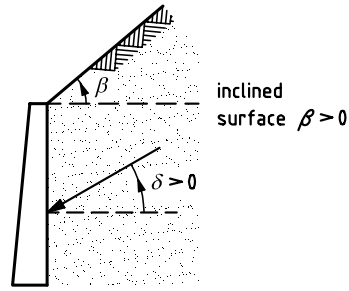

Figure C.1.3 — Coefficients K_a of effective active earth pressure (horizontal component): with inclined retained surface ($\delta/\varphi' = 0,66$)

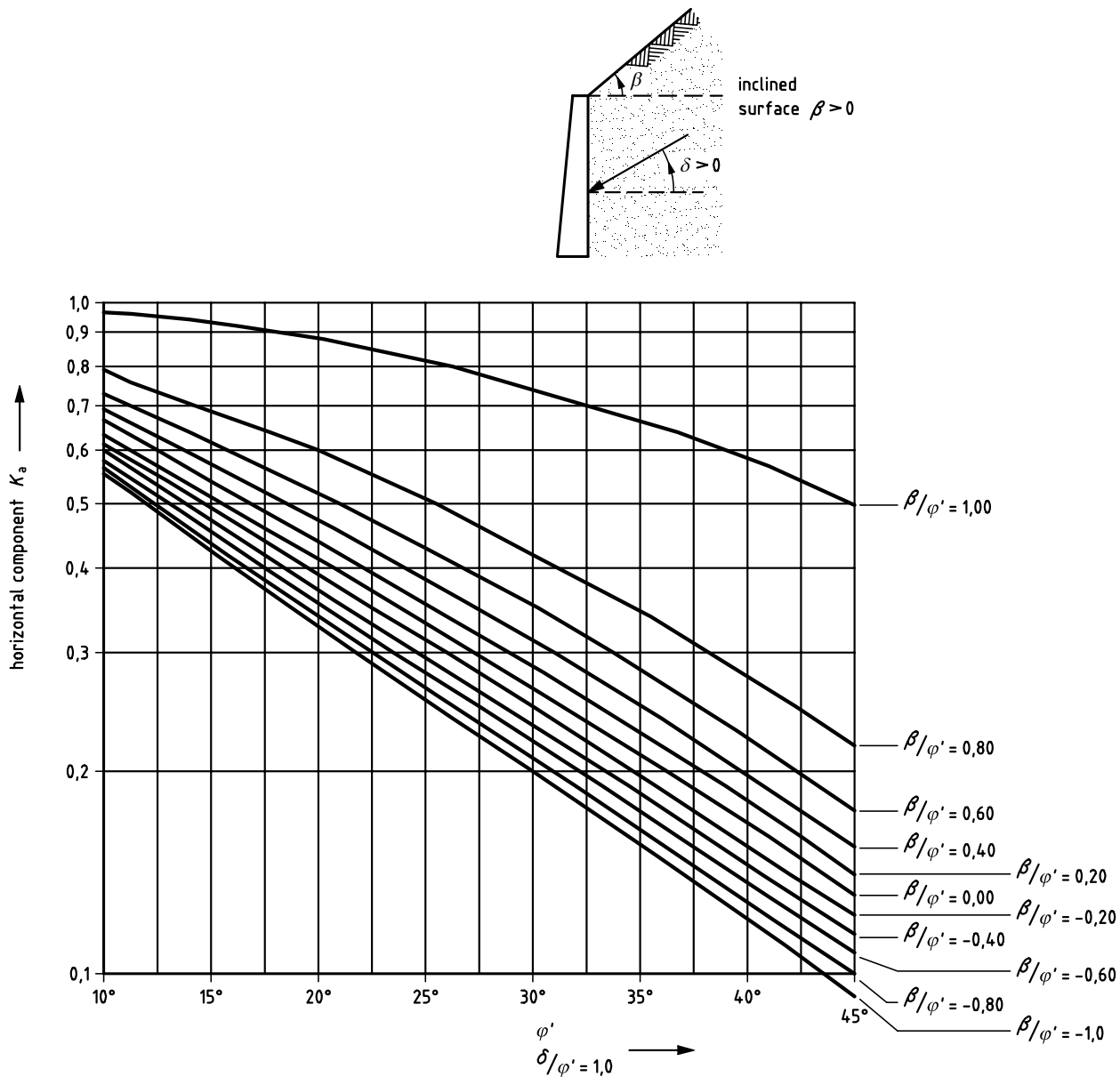

Figure C.1.4 — Coefficients K_a of effective active earth pressure (horizontal component): with inclined retained surface ($\delta/\varphi' = 1$)

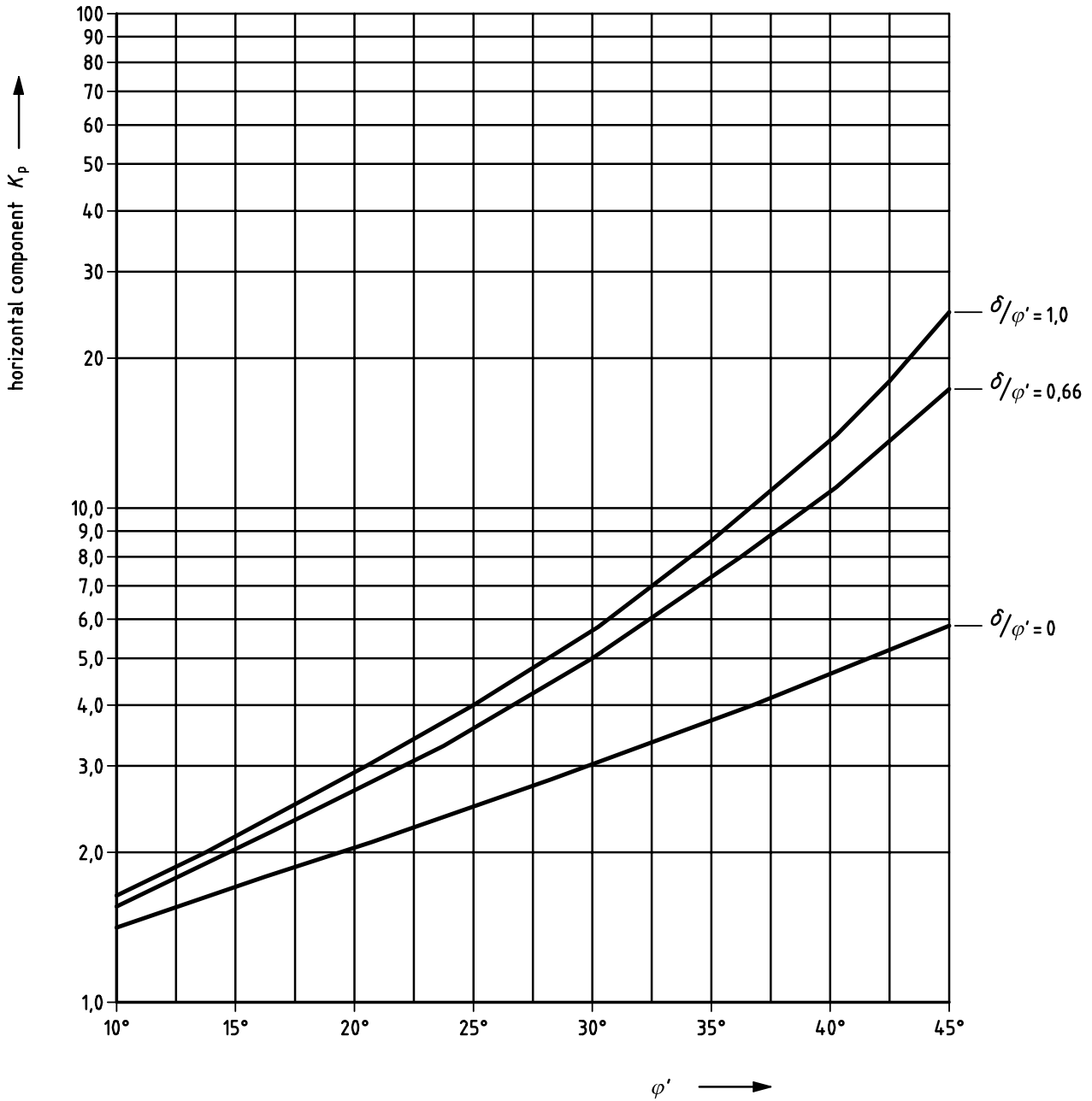
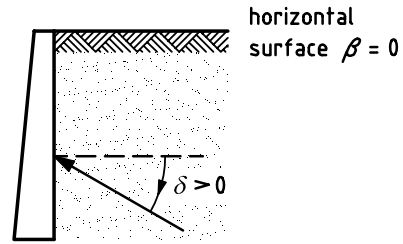

Figure C.2.1 — Coefficients K_p of effective passive earth pressure (horizontal component): with horizontal retained surface ($\beta = 0$)

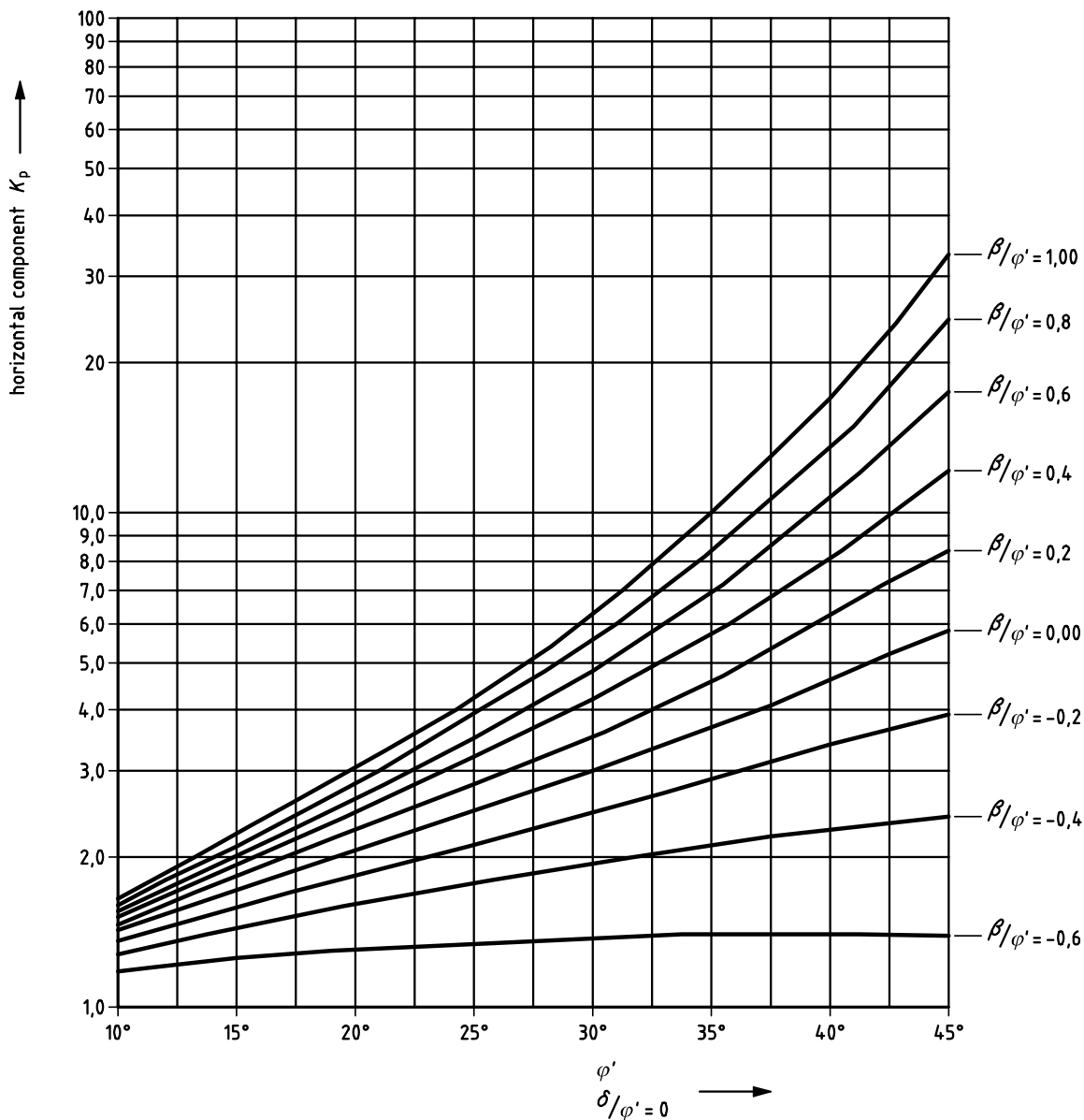
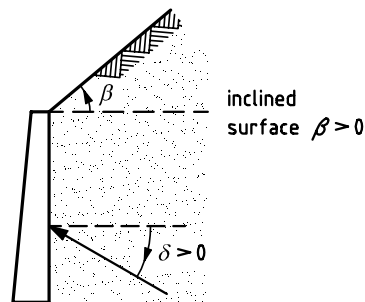

Figure C.2.2 — Coefficients K_p of effective passive earth pressure (horizontal component): with inclined retained surface ($\delta/\phi' = 0$ and $\delta = 0$)

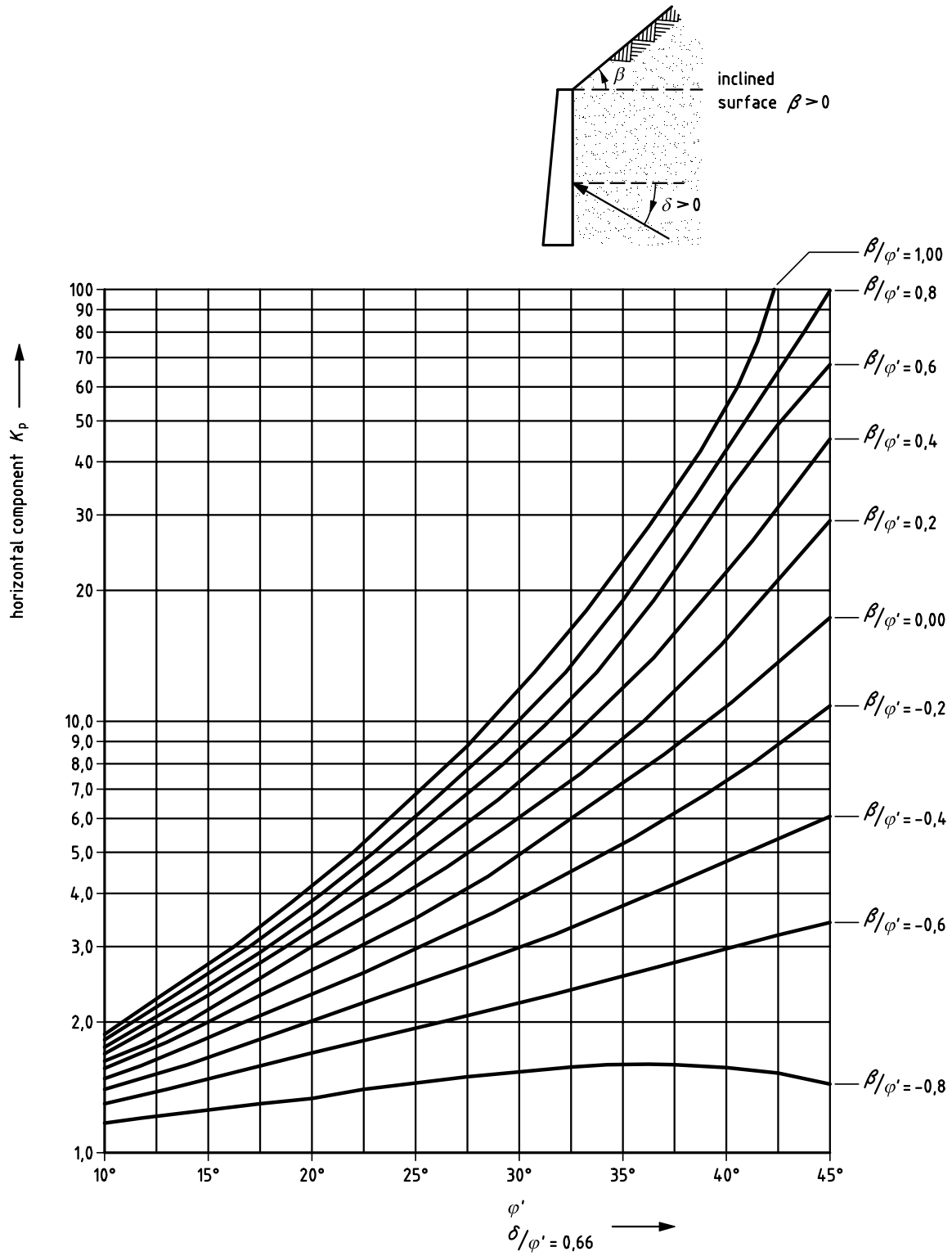

Figure C.2.3 — Coefficients K_p of effective passive earth pressure (horizontal component): with inclined retained surface ($\delta/\phi' = 0.66$)

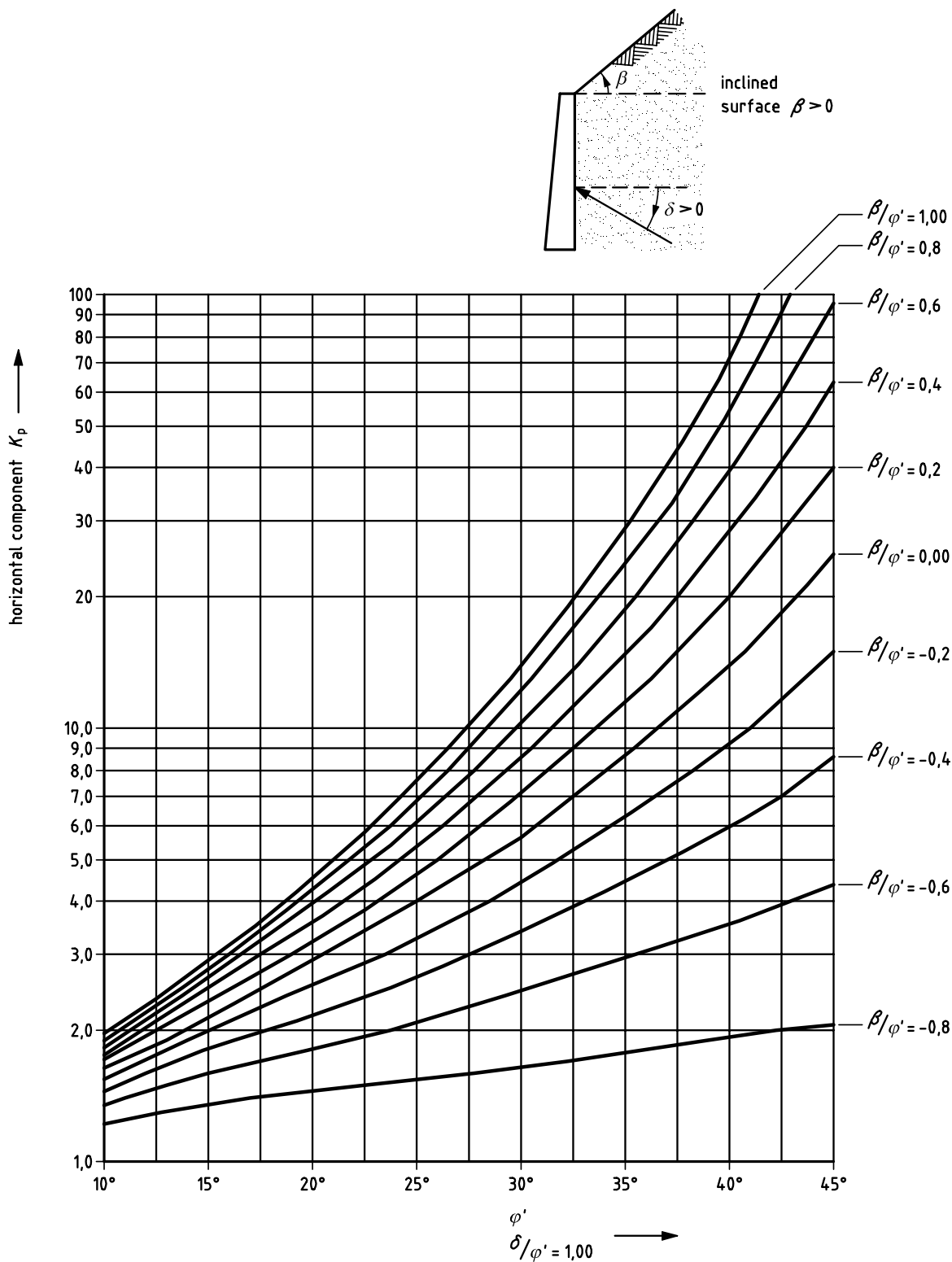

Figure C.2.4 — Coefficients K_p of effective passive earth pressure (horizontal component): with inclined retained surface ($\delta/\varphi' = 1$)

C.2 Analytical procedure for obtaining limiting active and passive earth pressures

(1) The following procedure, which includes certain approximations, may be used in all cases.

(2) The procedure is stated for passive pressures with the strength parameters (represented in the following by φ , c , δ , a) inserted as positive values, see Figure C.3.

(3) For active pressures the same algorithm is used, with the following changes:

- the strength parameters φ , c , δ and a are inserted as negative values;
- the value of the angle of incidence of the equivalent surface load β_0 is β , mainly because of the approximations used for K_γ .

(4) The following symbols are used (some are also given in 1.6):

- | | |
|------------|--|
| a | is the adhesion between wall and ground |
| c | is the cohesion |
| K_c | is the coefficient for cohesion |
| K_n | is the coefficient for normal loading on the surface |
| K_q | is the coefficient for vertical loading |
| K_γ | is the coefficient for the soil weight |
| m_t | is the angle from the soil surface direction, pointing away from the wall, to the tangent direction of the intersecting slip line that bounds the moving soil mass, pointing out from the soil surface |
| m_w | is the angle from the wall normal to the tangent direction at the wall of the exterior slip line, positive when the tangent points upwards behind the wall |
| β | is the angle from the horizontal to the soil surface direction, positive when the soil surface rises away from the wall |
| δ | is the angle of wall friction, with sign convention as defined in Figure C.4 when computing passive resistance |
| φ | is the angle of shearing resistance |
| θ | is the angle between the vertical and the wall direction, positive when the soil overhangs the wall |
| ν | is the tangent rotation along the exterior slip line, positive when the soil mass above this slip line is of a convex shape |
| q | is the general uniform surcharge pressure, per unit area of the actual surface |
| p | is the vertical uniform surcharge pressure, per unit area in a horizontal projection |

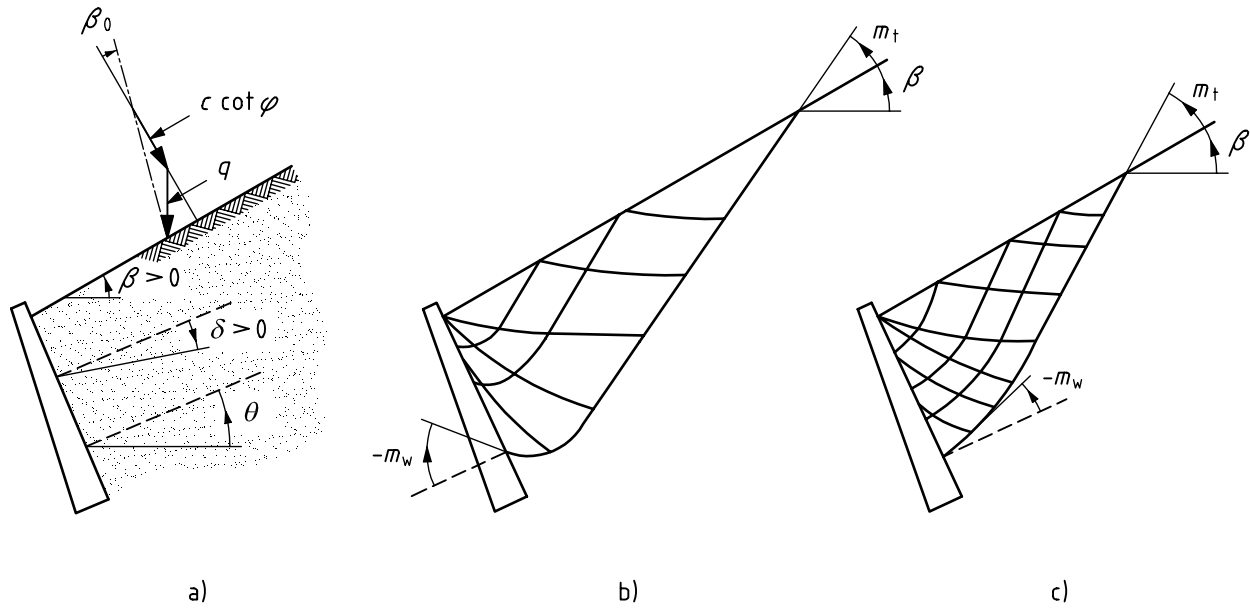

Figure C.3 — Definitions concerning wall and backfill inclination, surcharges and slipline geometry

(5) The interface parameters δ and a must be chosen so that:

$$\frac{a}{c} = \frac{\tan \delta}{\tan \varphi}$$

(6) The boundary condition at the soil surface involves β_0 , which is the angle of incidence of an equivalent surface load. With this concept the angle is defined from the vectorial sum of two terms:

- actual distributed surface loading q , per unit of surface area, uniform but not necessarily vertical, and;
- $c \cot \varphi$ acting as normal load.

The angle β_0 is positive when the tangential component of q points toward the wall while the normal component is directed toward the soil. If $c = 0$ while the surface load is vertical or zero, and for active pressures generally, $\beta_0 = \beta$.

(7) The angle m_t is determined by the boundary condition at the soil surface:

$$\cos(2m_t + \varphi + \beta_0) = -\frac{\sin \beta_0}{\sin \varphi} \quad (\text{C.3})$$

(8) The boundary condition at the wall determines m_w by:

$$\cos(2m_w + \varphi + \delta) = \frac{\sin \delta}{\sin \varphi} \quad (\text{C.4})$$

The angle m_w is negative for passive pressures ($\varphi > 0$) if the ratio $\sin \delta / \sin \varphi$ is sufficiently large.

(9) The total tangent rotation along the exterior slip line of the moving soil mass, is determined by the angle ν to be computed by the expression:

$$v = m_t + \beta - m_w - \theta \quad (\text{C.5})$$

(10) The coefficient K_n for normal loading on the surface (i.e. the normal earth pressure on the wall from a unit pressure normal to the surface) is then determined by the following expression in which v is to be inserted in radians:

$$K_n = \frac{1 + \sin\varphi \sin(2m_w + \varphi)}{1 - \sin\varphi \sin(2m_t + \varphi)} \exp(2v \tan\varphi) \quad (\text{C.6})$$

(11) The coefficient for a vertical loading on the surface (force per unit of horizontal area projection), is:

$$K_q = K_n \cos^2 \beta \quad (\text{C.7})$$

and the coefficient for the cohesion term is:

$$K_c = (K_n - 1) \cot\varphi \quad (\text{C.8})$$

(12) For the soil weight an approximate expression is:

$$K_\gamma = K_n \cos\beta \cos(\beta - \theta) \quad (\text{C.9})$$

This expression is on the safe side. While the error is unimportant for active pressures it may be considerable for passive pressures with positive values of β .

For $\varphi = 0$ the following limit values are found:

$$\cos 2m_t = -\frac{p}{c} \sin\beta \cos\beta;$$

$$\cos 2m_w = \frac{a}{c};$$

$$K_q = \cos^2 \beta;$$

$$K_c = 2v + \sin 2m_t + \sin 2m_w;$$

(with v in radians), while for K_γ ($\varphi = 0$), a better approximation is:

$$K_\gamma = \cos\theta + \frac{\sin\beta \cos m_w}{\sin m_t} \quad (\text{C.10})$$

(13) Both for passive and active pressures, the procedure assumes the angle of convexity to be positive ($v \geq 0$).

(14) If this condition is not (even approximately) fulfilled, e.g. for a smooth wall and a sufficiently sloping soil surface when β and φ have opposite signs, it may be necessary to consider using other methods. This may also be the case when irregular surface loads are considered.

C.3 Movements to mobilise earth pressures

(1) The relationship of earth pressures to wall movement should be considered for active situations. The magnitude of this movement depends on the mode of wall movement, the initial earth pressures and the density of the soil. Table C.1 gives approximate values for the ratio v_a/h for fully mobilised effective active earth pressure for a vertical wall with drained, non-cohesive soil and a horizontal ground surface, assuming an initial stress state with $K_0 < 1$.

(2) The relationship of earth pressures to wall movement should be considered for passive situations. The magnitude of this movement depends on the mode of wall movement, the initial earth pressures and the density of the soil. Table C.2 gives approximate values for the ratio v_p/h for fully mobilised effective passive earth pressure for a vertical wall with drained, non-cohesive soil and a horizontal ground surface, assuming an initial stress state with $K_0 < 1$. Values in brackets are the v/h ratios for half the limiting value of the effective passive earth pressure.

(3) Intermediate values of effective active earth pressure between the rest state and the limit state may be obtained by linear interpolation.

(4) For passive situations, values may be interpolated from those given in Table C.2 using a curve of the general form shown in Figure C.4.

Table C.1 — Ratios v_a/h for non-cohesive soils

Kind of wall movement		v_a/h loose soil %	v_a/h dense soil %
a)		0,4 to 0,5	0,1 to 0,2
b)		0,2	0,05 to 0,1
c)		0,8 to 1,0	0,2 to 0,5
d)		0,4 to 0,5	0,1 to 0,2
<p>where:</p> <p>v_a is the wall motion to mobilise active earth pressure</p> <p>h is the height of the wall</p>			

Table C.2 — Ratios v_p/h and v/h for $0.5\sigma_p$ for non-cohesive soils

Mode of wall movement		v_p/h (v/h for $0.5\sigma_p$) %	v_p/h (v/h for $0.5\sigma_p$) %
		loose soil	dense soil
a)		7 (1,5) to 25 (4,0)	5 (1,1) to 10 (2,0)
b)		5 (0,9) to 10 (1,5)	3 (0,5) to 6 (1,0)
c)		6 (1,0) to 15 (1,5)	5 (0,5) to 6 (1,3)
<p>where:</p> <p>v is the wall displacement</p> <p>v_p is the wall displacement to mobilise passive earth pressure</p> <p>h is the height of the wall</p> <p>σ_p is fully mobilised passive earth pressure</p>			

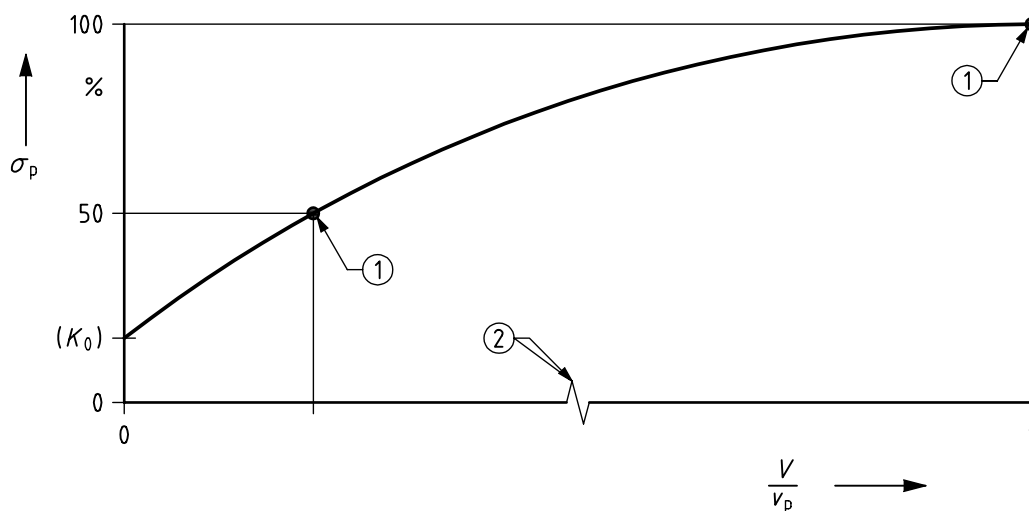

Key

1 values taken from Table C.2

2 not to scale

**Figure C.4 — Mobilisation of effective passive earth pressure of non-cohesive soil versus normalised wall displacement v/v_p
(v : displacement; v_p : displacement for the full mobilisation of passive earth pressure)**